

Grueneich

Stage Lighting Take-Home Test

Part 1 define the following terms:

1. Electrical Current:
2. Ampere (Amps):
3. Volts:
4. Circuit:
5. Resistance:
6. Ohms Law:
7. LCL (Light Center Length):
8. Fluorescence:
9. Electrical Connectors:
10. Watts

LABEL THE FOLLOWING PICTURE FROM YOUR NOTES:

11, 12, and 13 Parts of the filament lamp:

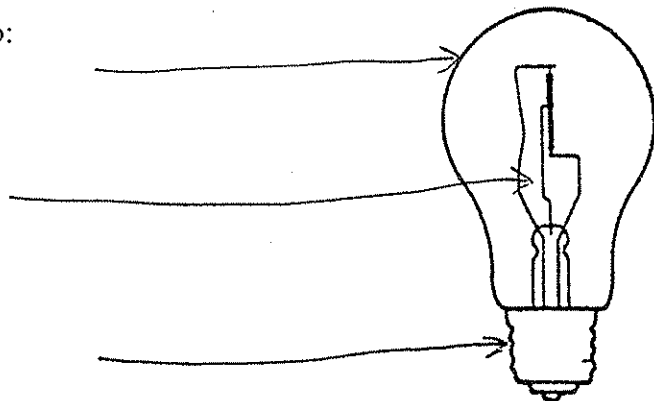

14. Please list the four types of lamp Bases

A. _____ Least expensive, least accurate

B. _____ Most Accurate, *Low Wattage*

C. _____ Most Accurate, older equipment

D. _____ Accurate High Wattage, older equipment

15. LABEL THE PARTS OF FRESNEL:

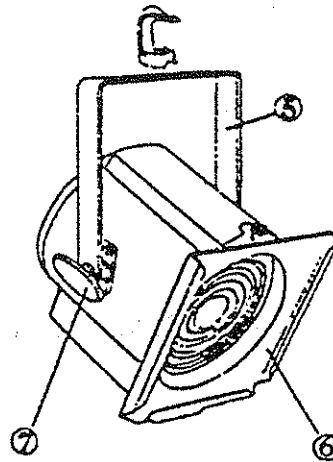
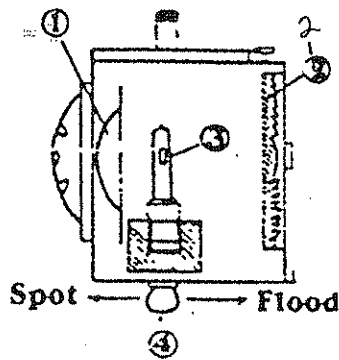

1. _____
2. _____
3. _____
4. _____
5. _____
6. _____
7. _____

16. Why is a Fresnel instrument called a Fresnel?

17. What does ERS stand for?

18. Why do we often refer to the ERS as a LEKO?

19. What type of Lekos does Klein ~~Collins~~ own? The Axial or Base up model?

20. LABEL THE SCOOP:

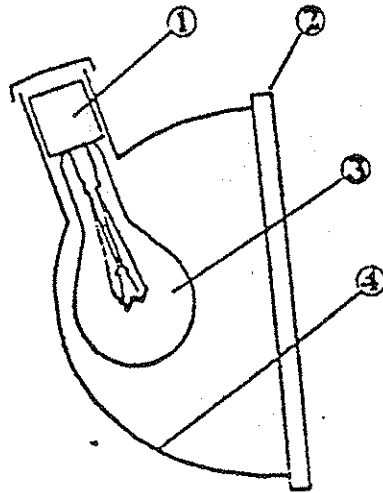

1. _____.

2. _____.

3. _____.

4. _____.

21. What are some uses for the scoop?

22. What are some uses for the Leko?

23. What are some uses for the Fesnel?

IDENTIFY THE FOLLOWING PICTURES

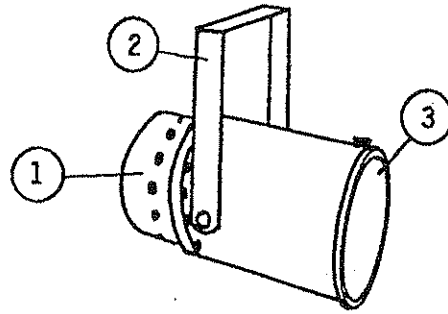

24. _____

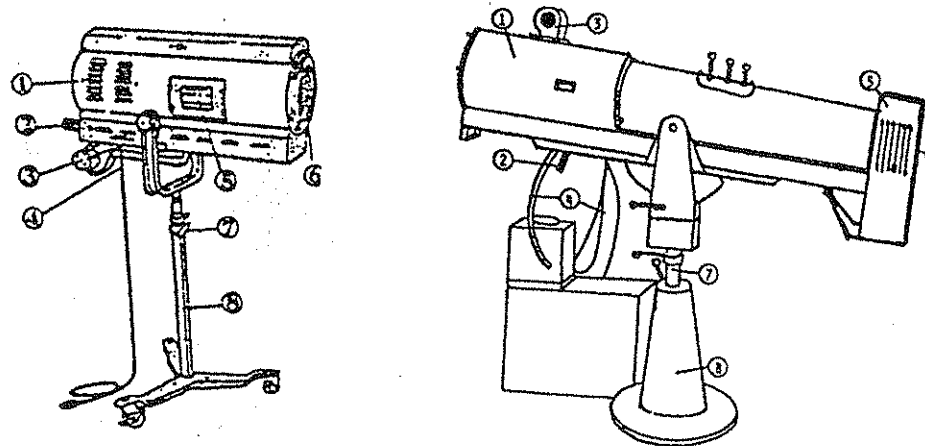

25. _____

26. List three potential hazards when working with lighting equipment?

27. List three safety rules concerning stage lighting equipment.

28. What are the colored round pieces of glass that are used to color the light beams of striplights called?

29. What is the color plastic media which we use to color the light in modern instruments called?
- 30, 31, 32, 33. List the four types of electrical connectors.
- 34, 35, 36. **List and Describe** the three types of circuit breakers.
37. There is no number 37.
38. What is the **purpose** of the control section (control console) in a stage lighting control system?
39. What was the first form of stage lighting?
40. What is 16th century (1500 – 1600) Italian Leone di Soni state about lighting in Tragedy and Comedy?
41. What were some of the problems with using oil lamps?
42. What was gas lighting an improvement over oil lamps and candles?
43. What was one of the major safety concerns when using gas lighting?
44. What were some of materials the 1st reflectors made of? (17th century)
45. **List and define** the four functions of light:

46. **List** and **Define** the four qualities of light:

47. There is no 47.

48 and 49. What are two ways of creating the above qualities of light?

50. Explain Light adaptation, Dark adaptation and Transient adaptation in relation to how the eye works.

51. Provide a detailed explanation of how to record a lighting cue using the light board in the auditorium.

52. Which channel on the light board are the house lights assigned to?

USING Formula: $\text{Watts} = \text{Volts} \times \text{Amps}$

53. You have been given the job of Master Electrician for the Thespis Theatrics Theater Company. You thought this would be a really neat job having this 1200 seat converted barn to work in. You have made a terrible discovery regarding your electric system. You have your standard 120VAC source, however, you are the proud new owner of Fifty 100 watt lighting instruments and only a 15 amp breaker box. How many lighting instruments can you use?
54. Have left the Thespis company after a rather nasty shock leaving your hair looking something like your former high school tech director. You have decided to work as an electrician at the Acme Regional Theater group. Once again find yourself having to deal with non standard electrical systems. You have to hook up 20 6 x 12 Lekos which use 750 watt lamps. You have a 150 amp circuit (very scary, Yikes!). Please figure out what voltage your system needs to supply to run your system.
55. After successfully pleading innocent to charges of setting the Acme Theater on fire you have landed your next electrician job at the Final Curtain Playhouse. Although this is a small theatre with a normal 120VAC system you still have a tough job on your hands. You have 8 500watt fresnels and 2 1000 watt followspot. How many amps do you need to run your system?

